

Fully Welded Ball Valves

PN40/600PSI/Class300

Reduced Bore, lever Handle, Fixed Ball
Design to EN488
Pressure Test to EN12266.1

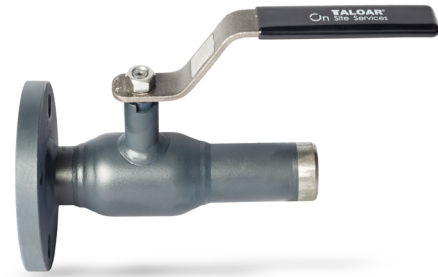

WB3523-L
FXS

Materials list		
1	Body	A106-B, EN10217-2
2	Welded Pipe	A106-B, EN10217-2
3	Spring	AISI 304, EN10088-3
4	Fireproof Gasket	AISI 304
5	O-Ring	Viton
6	Seat Ring	PTFE 25%C
7	Ball	AISI 304, EN10088-3
8	Stem Guide	A106-B, EN10217-2
9	Stem	ASTM A420, EN10088-3
10	Thrust Washer	PPL
11	O-Ring	Viton
12	O-Ring	Viton
13	Packing	Graphite
14	Gland	A106-B, EN10217-2
15	Pin	ASTM 1566
16	Lever Handle	AISI 1020

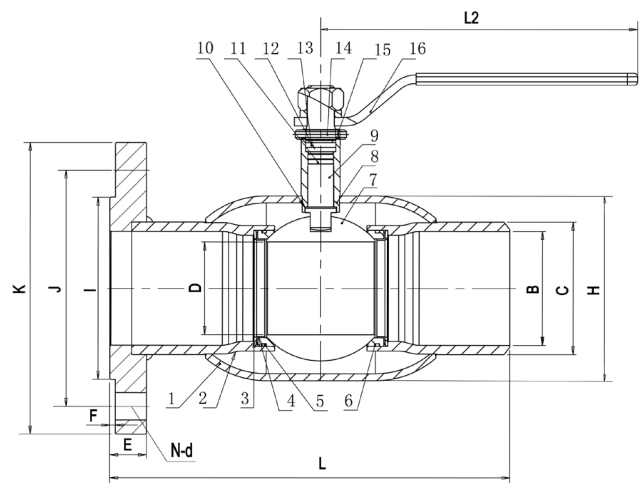

* Operating temperature range: -30°C ~ +200°C .
* For other materials and special requirements, please consult the factory or the local offices.

Dimensions/Weights															
In	D	B	C	H	I	J	K	E	F	N-d	L	L2	Kvs	Lbs	Kg
½	10	16	21	34	45	65	95	16	2	4-Φ14	180	220	8	4.0	1.8
¾	15	19	27	42	55	75	105	16	2	4-Φ14	190	220	15	5.1	2.3
1	20	26	34	48	65	85	115	16	2	4-Φ14	195	220	26	6.4	2.9
1¼	25	34	42	60	78	100	135	18	2	4-Φ18	220	220	40	8.6	3.9
1½	32	40	48	76	85	110	145	18	3	4-Φ18	230	265	68	10.4	4.7
2	40	50	60	83	100	125	160	20	3	4-Φ18	265	265	112	15.2	6.9

* Please consult the engineers for full-bore dimensions.